



Simple,

Solid,

Safe



SALVAMAC

AIR & PAINTING





#AIR

AIR EXPRESS SELECTION



AIR SOLUTION 4 YOU





AIR EXPRESS SELECTION

MOBILE DUST EXTRACTORS

HOSE FILTER (SLEEVES)

COMPONENTS

AIR EXPRESS SELECTION

Simple, Solid, Safe





MOBILE DUST EXTRACTORS

TROLLEY BAG

TROLLEY CARTIDGE

AIR EXPRESS SELECTION

Simple, Solid, Safe



WHY MOBILE?

- Small space
- Moving from one machine to another
- Inside and for Provisional/Temporary use(open/close depending by local legislation)



TROLLEY BAG



- System with cotton weave bags
- For fine dust and chips

TROLLEY CARTIDGE



- System with cartridges filters
- Only for fine dust

MOBILE DUST EXTRACTORS TROLLEY BAG

Series “TROLLEY BAG” exhausters are ideal for small-scale work and for those who operate in a limited space

Perfect for:

SMALL CAPACITY

SMALL SPACE

MOBILE AND TEMPORARY USE

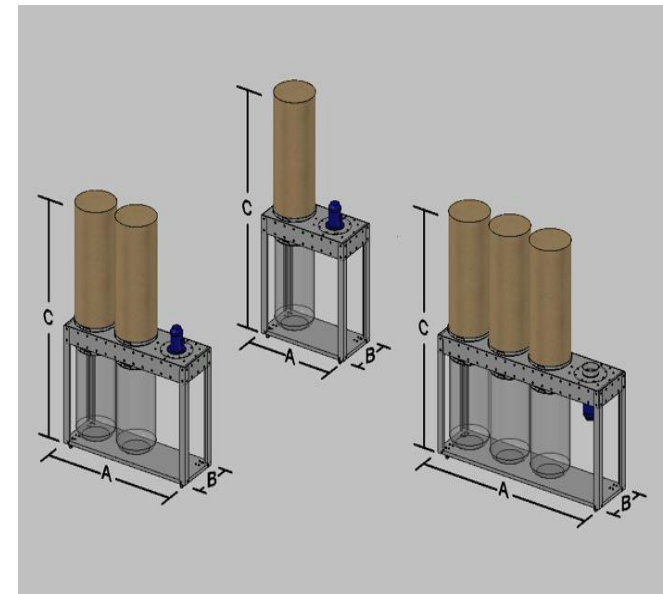

AIR EXPRESS SELECTION

MOBILE DUST EXTRACTORS TROLLEY BAG

SOLIDITY AND QUALITY AT TOP LEVEL

Possibility to have version with upper closing with or without ATEX.

Possibility to have painted version.



MODEL	TROLLEY BAG 1	TROLLEY BAG 2	TROLLEY BAG 3	TROLLEY BAG 4
Motor	Three-Phase			
Power	2 HP (1,5 Kw)	3 HP (2,2 Kw)	5,5 HP (4 Kw)	7,5 HP (5,5 Kw)
Filtering bags H=1200	01 Ø 500 mm	02 Ø 500 mm	03 Ø 500 mm	04 Ø 500 mm
Collecting bags PVC	01 Ø 500 mm	02 Ø 500 mm	03 Ø 500 mm	04 Ø 500 mm
Dimension a x b x c	1.180x580x2.460	1.730x580x2.460	2.280x580x2.460	2.840x580x2.460
Air Flow mc/h	2.000	2.500	4.000	6.000

MOBILE DUST EXTRACTORS TROLLEY CARTIDGE

Series "TROLLEY CARTRIDGE" exhausters are ideal for small-scale work and for those who operate in a limited space.

Series " "TROLLEY CARTRIDGE" " is a cartridge filter build in press-bent galvanized sheet iron. It is indicated for aspiration of fine dust in general.

It is equipped with a cartridge cleaning system through opposing lamellas positioned in the center of cartridge and actuated by an electric motor.

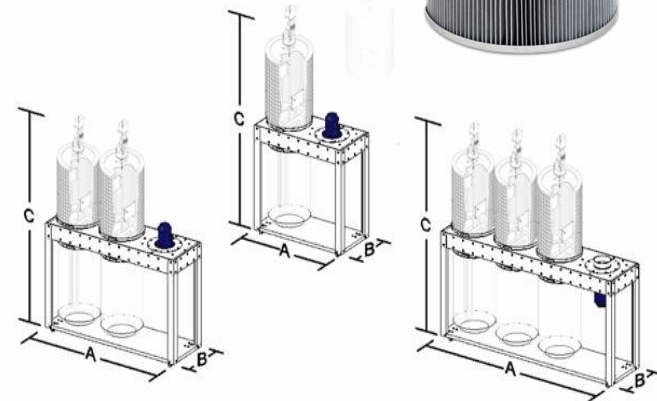
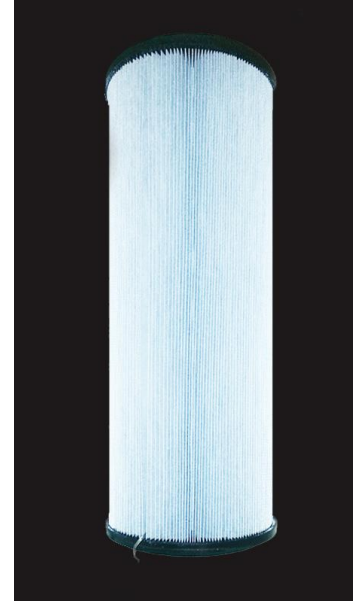

MOBILE DUST EXTRACTORS TROLLEY CARTIDGE

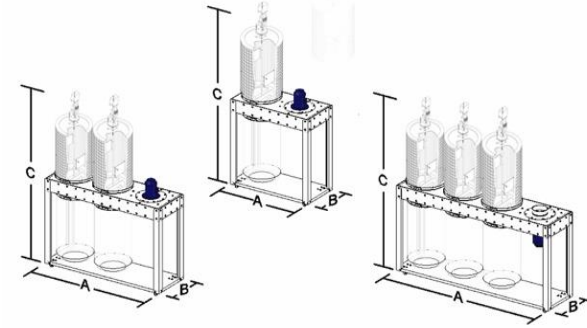

The "TROLLEY CARTRIDGE" filter is completed of a electric control panel with 2 automatic timers.

After 2 minutes from snitching off the electric motor, you start the cleaning system for approx. 10/15 seconds.

Possibility to have version with upper closing with or without Atex.
Possibility to have painted version.

MODEL	TROLLEY CARTRIDGE 1	TROLLEY CARTRIDGE 2	TROLLEY CARTRIDGE 3	TROLLEY CARTRIDGE 4
Motor	Trifase			
Power	2 HP (1,5 Kw)	3 HP (2,2 Kw)	5.5 HP (4 Kw)	7,5 HP (5.5 Kw)
Filtering bags H=1200	01 Ø 500 mm	02 Ø 500 mm	03 Ø 500 mm	04 Ø 500 mm
Collecting bags PVC	01 Ø 500 mm	02 Ø 500 mm	03 Ø 500 mm	04 Ø 500 mm
Dimension a x b x c	1.180x580x2.400	1.730x580x2.400	2.280x580x2.400	2.840x580x2.400
Air Flow mc/h	2.000	3.000	5.500	7.000



HOSE FILTER (SLEEVES)

COMPACT BASIC

COMPACT PLUS

COMPACT SUPER

AIR EXPRESS SELECTION

 **SALVAMAC**
AIR & PAINTING



WHY COMPACT SERIE?



- Really Compact with more capacity.
- Inside/ Outside the factory
- Possibility to have shaker, firefighting technology...

BASIC

- Small capacity
- Open or Closed
- Price fantastic

PLUS

- Medium Capacity
- Only Closed
- Possibility to have shaker
- Quality

SUPER

- Big Capacity and efficiency
- Only Closed
- Mechanic or pneumatic Cleaning
- The top

HOSE FILTER (SLEEVES) COMPACT BASIC-PLUS

Made with galvanized sheet iron (not painted)

“COMPACT BASIC” and “COMPACT PLUS” series filters are ideal for the filtering of all types of materials and dusts, with the exception of explosive and detonating material.

The structure with press-bent galvanized sheet iron makes the transport and the assembly easy.



HOSE FILTER (SLEEVES) COMPACT BASIC

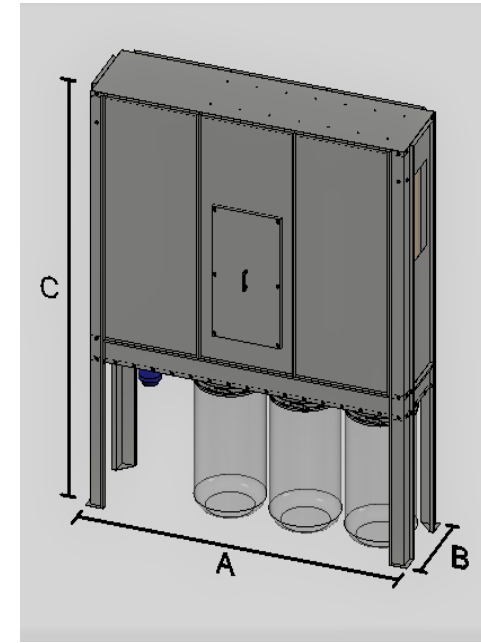
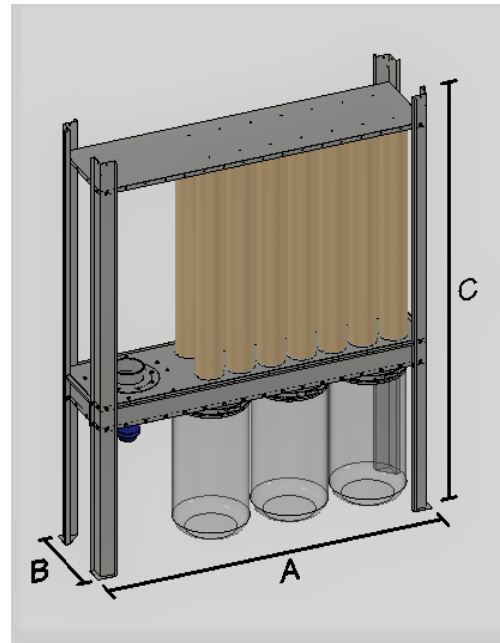

Possibility to have version with upper closing with or without Atex.

MODEL	COMPACT BASIC 2	COMPACT BASIC 3	COMPACT BASIC 4	COMPACT BASIC 5
Dimension A x B x C	1.800 x 640 x 2.880	2.350 x 640 x 2.880	2.900 x 640 x 2.880	2.900 x 640 x 2.880
Power	3 HP	4 HP	5,5 HP	7,5 HP
N° hoses \varnothing 180	8	12	16	16
Hoses Height	1.500 mm	1.500 mm	1.500 mm	1.500 mm
Snap-ring	Si / Yes	Si / Yes	Si / Yes	Si / Yes
Air Capacity	2.500	3.000	4.000	5.000
N° collecting bags	2 \varnothing 500	3 \varnothing 500	4 \varnothing 500	4 \varnothing 500

HOSE FILTER (SLEEVES) COMPACT PLUS

Possibility to have version with Atex

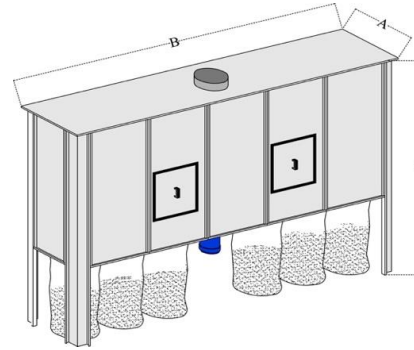

MODEL		COMPACT PLUS 4	COMPACT PLUS 6	COMPACT PLUS 4 S (shaker)	COMPACT PLUS 6 S (shaker)
A (mm)		775	775	775	775
B (mm)		2.900	4.000	2.900	4.000
C (mm)		2.900	2.900	3.200	3.200
N° sleeves		12	20	12	20
H sleeves		1.500	1.500	1.500	1.500
D. Filtering sleeves		180	180	180	180
Snap-ring		Yes	Yes	Yes	Yes
Q max mc/h	Shavings	3.500	5.000	3.500	5.000
	Dusts	2.000	3.000	2.500	3.500
N° collection bags		4 Ø 500	6 Ø 500	4 Ø 500	6 Ø 500
Shaker		No	No	1 x 0,1 Hp	1 x 0,1 Hp
Power - hp		5,5	7,5	5,5	7,5

HOSE FILTER (SLEEVES) COMPACT SUPER

*HIGH TECHNOLOGY MOBILE ASPIRATORS WITH AIR
COMPRESSED AUTOMATIC CLEANING SYSTEM*

Wood workers in the industrial and artisan sector will benefit from this series of COMPACT SUPER filter groups.

They are very versatile filtering groups, they occupy little space, they are self-cleaning and are suitable to suck up both powders and wood shavings.

All models reach a residual powder content of less than 0.1 mg./mc. and conform to the residual dust level H3.

The fan is positioned in such a way as to obtain a negative pressure that prevents the leakage of dust in case of lack of tightness.

HOSE FILTER (SLEEVES) COMPACT SUPER

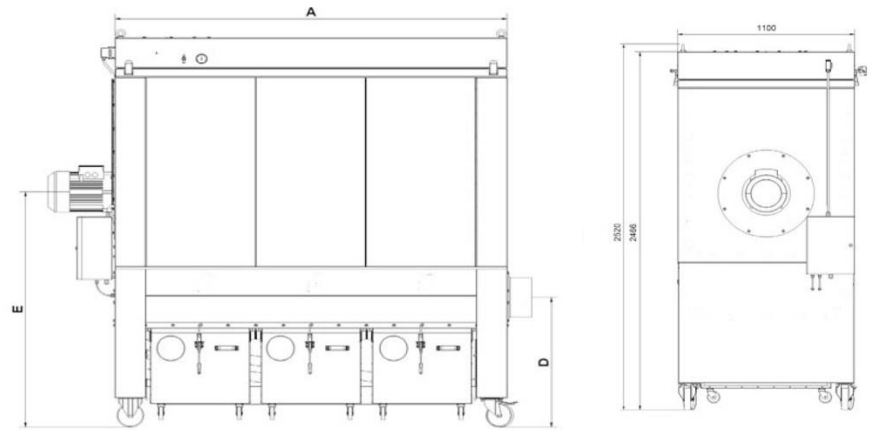

They are available in four models to satisfy the most varied and complex needs of the customer.

Perfect distribution of the chips in the containers and very high suction performance as the filters are kept by the system always clean.

The automatic cleaning (mechanical or pneumatic) is standard and is already included in the price.

Possibility to have version with Atex

MODEL	COMPACT SUPER 24	COMPACT SUPER 36	COMPACT SUPER 48	COMPACT SUPER 60
Suction	200R	250 R	300 R	350 R
Power	4 HP	5,5 HP	7,5 HP	10 HP
Air capacity	1.800 Mc/h	3.200 Mc/h	4.600 Mc/h	6.100 Mc/h
Wheeled collection bins	1 200 lt.	2 400 lt.	3 600 lt.	3 600 lt.
A (mm) x B (mm)	1.160 x 1.630	1.600 x 2.070	2.200 x 2.730	2.200 x 2.730
Pression	2.500 Pa	2.800 Pa	3.200 Pa	3.600 Pa
Filtering media	Needle polyester felt	Needle polyester felt	Needle polyester felt	Needle polyester felt

HOW TO CHOOSE ?



By adding the flow rate of the suction inlets that work at the same time, you will have the effective flow that you need and you will be able to identify the filtering group that best suits your needs.

Identify the suction mouths of the machines that work simultaneously		
DIAMETER MM	SPEED - 25 MT/SEC AIR FLOW MC/H	SPEED - 30 MT/SEC AIR FLOW MC/H
80	450	542
100	705	846
120	1.016	1.219
150	1.588	1.905
200	2.823	3.387
250	4.411	5.293

To determine the suction speed required for each machine, consult the use and maintenance manual of the machine to be connected.

We would like to point out that this calculation may not be reflected in case of excessive lengths of the processing room or of various impediments to be analyzed at the time of the survey.

HOW TO CHOOSE?



- 1 Traditional machine (1 Diam. 150 mm. 1600 m³/h):
TROLLEY BAG 2 or COMPACT BASIC 2



- 2 Traditional machines (1 Diam. 150 mm. + 1
Diam. 150 mm. 3200 m³/h):
COMPACT BASIC 4 or COMPACT PLUS 4 S.



- 1 CNC (1-Diam. 250 mm. 5000 m³ /h):
COMPACT PLUS 6 / S Optional

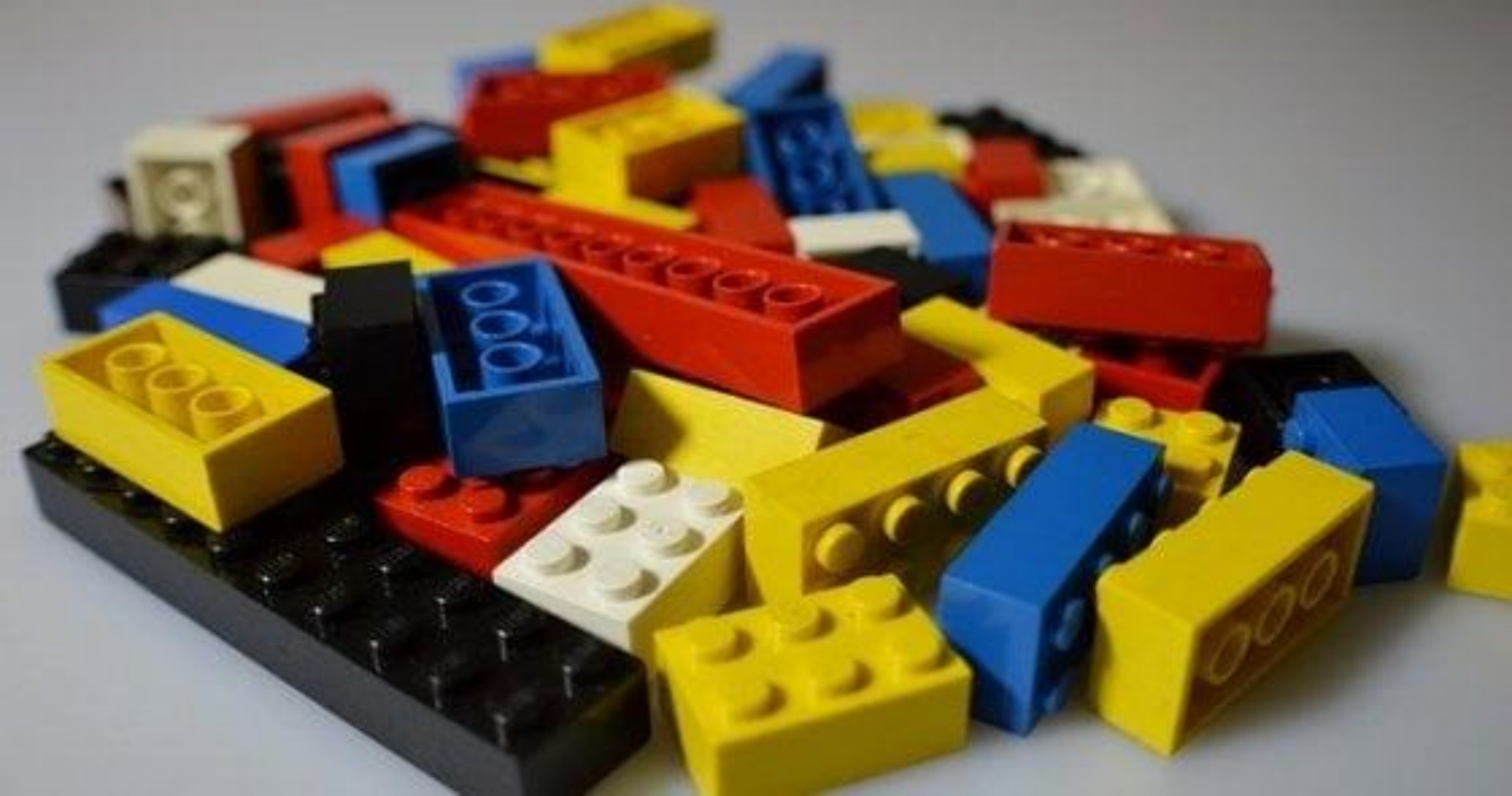

COMPONENTS

AIR EXPRESS SELECTION

 **SALVAMAC**
AIR & PAINTING



COMPONENTS

Pipes

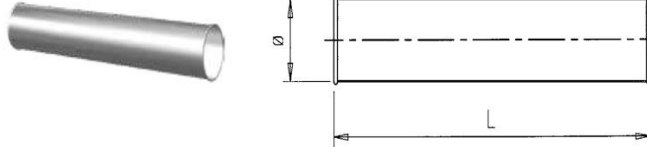

Collectors with flap

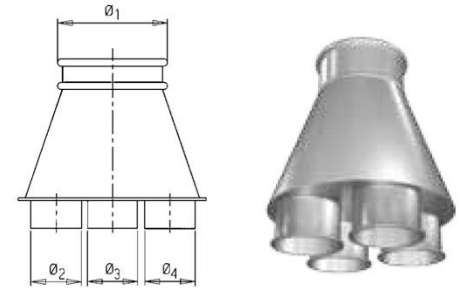

Reduction Cones

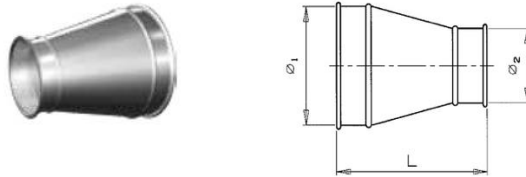

Superflex PU Pipes



Curves with flap

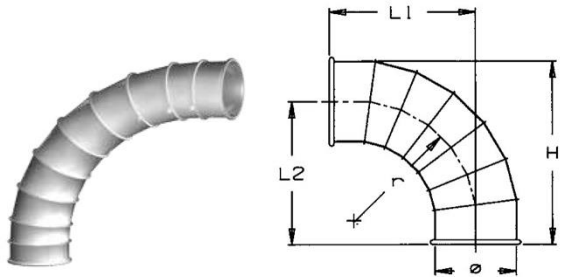

Section Changes

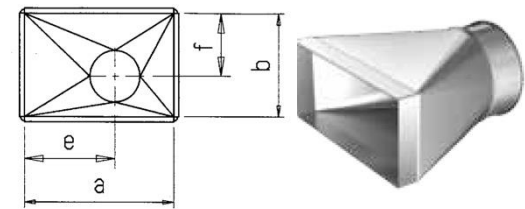

Deviations with flap

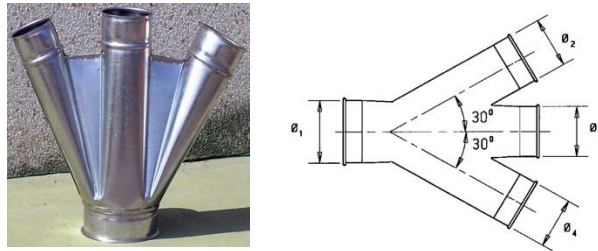

Collars

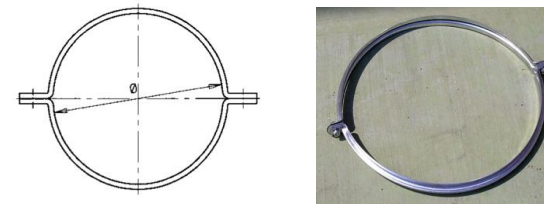

COMPONENTS

ACA

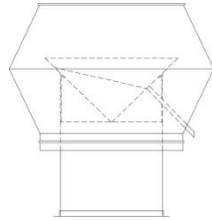

Guillotine Shutters

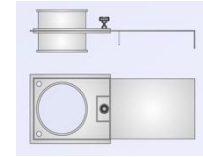

Terminals with Net

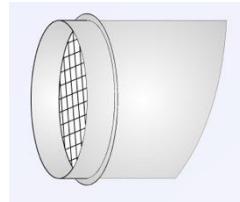

Printed Flanges



Butterfly Shutters

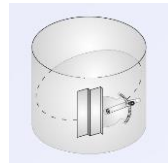

Revolted Antivibrating Joints



Chain Shutters

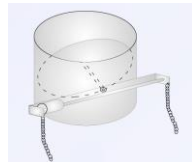

Afon Pipes





AIR SOLUTION 4 YOU

AIR SOLUTION 4 YOU



ASPIRATION FOR YOUR FACTORY

We develop engineering processes aimed at building plants for air intake and filtration while paying utmost attention to energy savings and pollution. We have been substantially contributing to improving the quality of work and to reducing pollution generated by industrial processes for over 30 years.



AIR SOLUTION 4 YOU

ASPIRATION FOR YOUR FACTORY

The personalization means the development of technical solutions that can meet the needs of small and medium-size companies that are involved in a number of types of processing on a daily basis and that need high efficiency, small plants and advantageous costs.



AIR SOLUTION 4 YOU

FILTERING SILOS

Highly innovative silos and filtering units with a remarkably advanced new generation technology suitable for storing material.

They are equipped with all the technical (anti-compacting bridgebreaker system, controlled speed extraction system) and safety (ATEX directional and explosion protection system, safety and inspection system, fire protection system) devices.



HIGH TECHNOLOGY

The Air Intake and Purification Plants are produced by seeing to all phases of the process cycle:

from measurements
and design to estimating the
execution of every single
component at the various
production sites.



AIR SOLUTION 4 YOU

A SOLUTION FOR ALL

- Inspection and analysis of the problems;
- Engineering study and development of the plant;
- Technical/economic feasibility study;
- Negotiation and definition of the plant;
- Production of the working drawings, specifications and bills of quantities;
- Construction, transport, assembly and testing;
- After-sale service

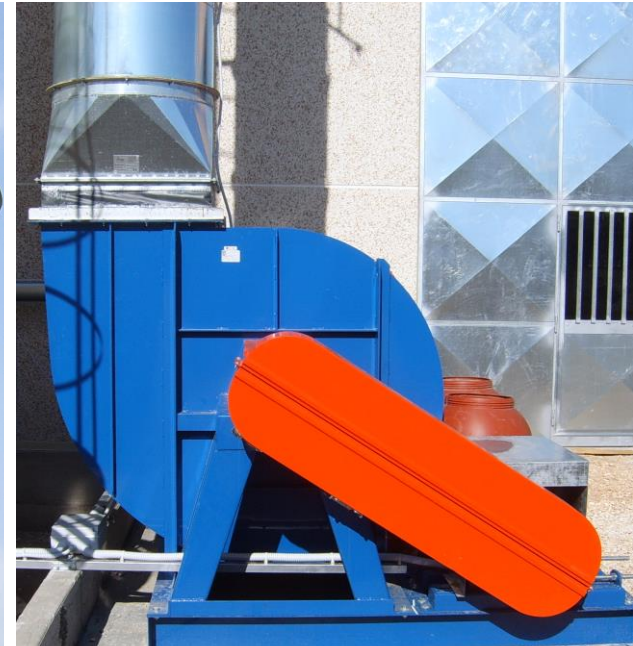

#PAINTING

PAINTING EXPRESS SELECTION



PAINTING SOLUTION 4 YOU





Simple,

Solid,

Safe

PAINING EXPRESS SELECTION

AIR EXPRESS SELECTION

 **SALVAMAC**
AIR & PAINTING



PAINING BOOTH PICASSO - DRY

Built in modular sandwich panels (thickness 40 mm.)

The painting booth is built in modular sandwich panels (thickness 40 mm), pre-painted on both sides white/grey color with details on galvanized sheet metal bended.

Standard equipment "PICASSO DRY":

- 1. Electric fan,*
- 2. Andrae filter,*
- 3. Cells with paint-stop,*
- 4. Circuit breaker,*
- 5. Emergency button.*

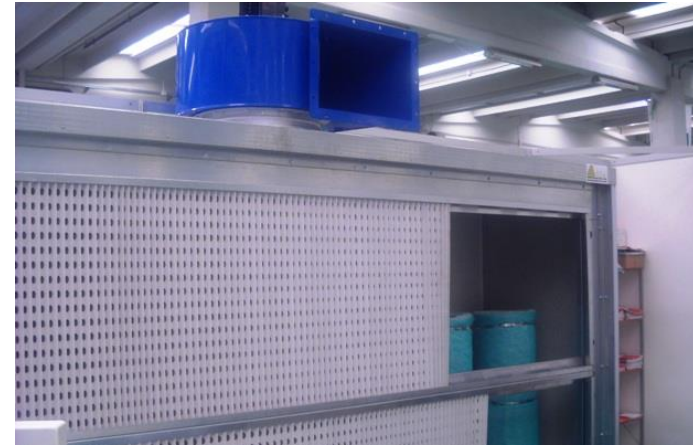

PAINING EXPRESS SELECTION

PAINING BOOTH PICASSO - DRY

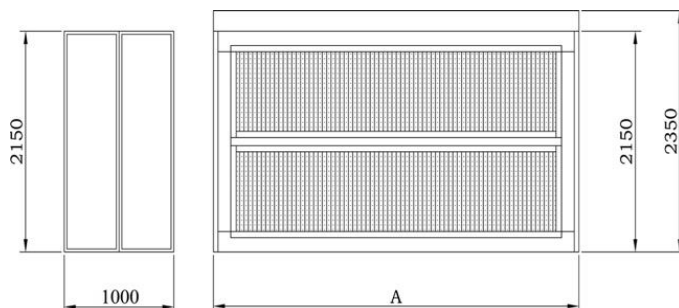

MODEL	A mm	Illumination N x W	Power (CA) - Kw	Cs capacity Mc/h
PICASSO DRY 200	2.000	NO	350/4 - 2,2	8.000
PICASSO DRY 300	3.000	NO	350/4 - 3	11.000
PICASSO DRY 400	4.000	NO	350/4 - 4	15.000
PICASSO DRY 500	5.000	NO	400/4 - 5,5	16.500
OPTIONAL				
Illumination N x W	Deep module L = 500 mm	Aspirator + ceiling lights ATEX		



WATER BASED PAINTING BOOTH PICASSO - DRY

Made with galvanized sheet iron (not painted)

The painting booth series “PICASSO WATER” are indicated for aspiration and filtration for pigments and fures emitted in the process of spray painting made with synthetic solvents, organic or water, decanting plenum and paint-stop filter. Constructed of galvanized sheet metal panels bended.

Standard equipment series “PICASSO WATER”:

1. Electric fan,
2. Front galvanized veil manually liftable,
3. Support veil,
4. Paint-stop filter,
5. Electric panel control,
6. Ceiling light,
7. Electric pump immersion,
8. Metal filter,
9. Emergency button,
10. Analog hour meter,
11. Change of section.

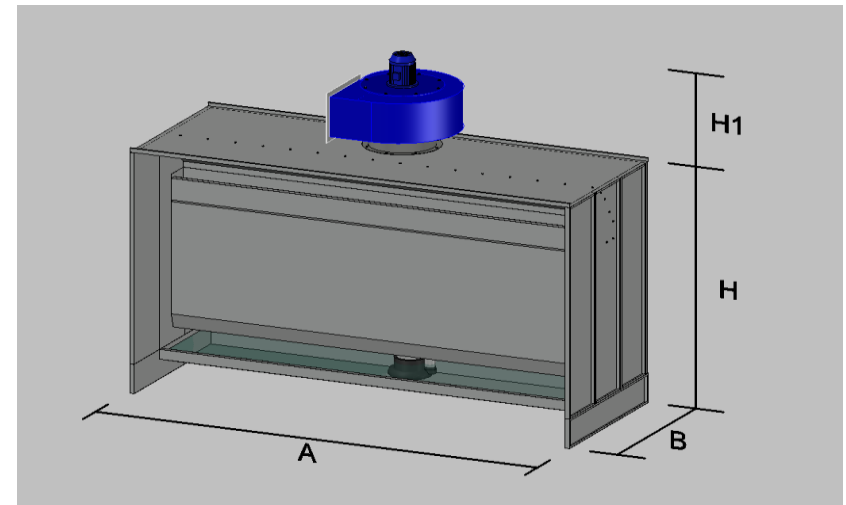

PAINTING EXPRESS SELECTION

WATER BASED PAINTING BOOTH PICASSO - DRY

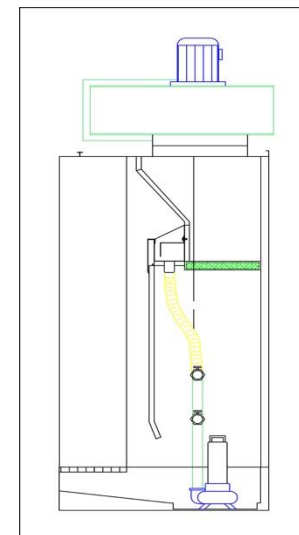
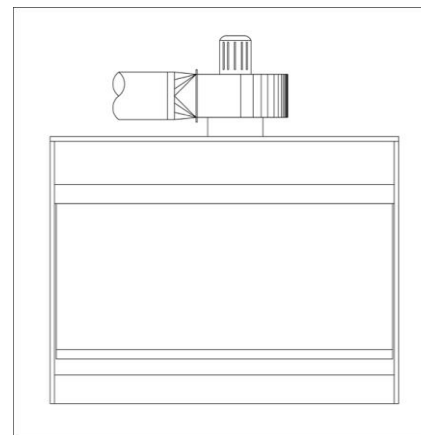

MODEL	A x B mm	Illumination N x W	Power Kw	Power Mc/h	Version (1 veil)	Version (double frontal veil)
PICASSO WATER 200	2.000 x 1.200 x 2.450	2 x 36	1,5	8.000	1 Veil	Double frontal Veil
PICASSO WATER 300	3.000 x 1.200 x 2.450	2 x 58	2,2	11.000	1 Veil	Double frontal Veil
PICASSO WATER 400	4.000 x 1.200 x 2.450	2 x 58	4	15.000	1 Veil	Double frontal Veil
PICASSO WATER 500	5.000 x 1.200 x 2.450	4 x 58	5,5	22.000	1 Veil	Double frontal Veil
OPTIONAL						
	Deep Module L = 500 mm		Aspirator + ceiling lights ATEX		Inverter Aspirator	

MINI PAINTING BOOTH PICASSO - MINI

Made with galvanized sheet iron (not painted)

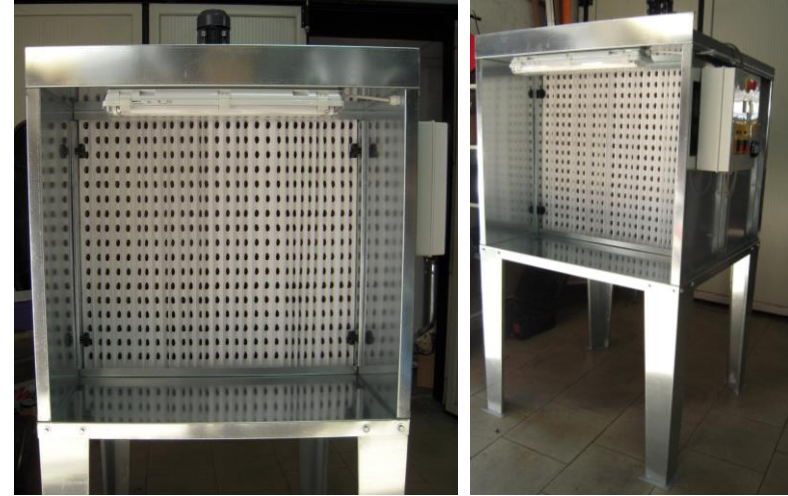

The painting booth series “PICASSO MINI DRY” and “PICASSO MINI WATER” are indicated for aspiration and filtration of pigments and fumes emitted in the process of spray painting made with synthetic solvents, organic or water.

The reduction is carried out made a suction wall with andreae filter and paint-stop filter. It is mainly used for painting small objects, for test of painting in laboratory. Constructed of galvanized sheet metal panels bended.

Standard equipment PICASSO MINI DRY:

1. Electric fan,
2. Andreae filter,
3. Paint-stop filter,
4. Electric panel control.

Standard equipment PICASSO MINI WATER:

1. Electric fan,
2. Front galvanized veil,
3. Paint-stop filter,
4. Electric panel control,
5. Electric pump.

MINI PAINTING BOOTH PICASSO - MINI

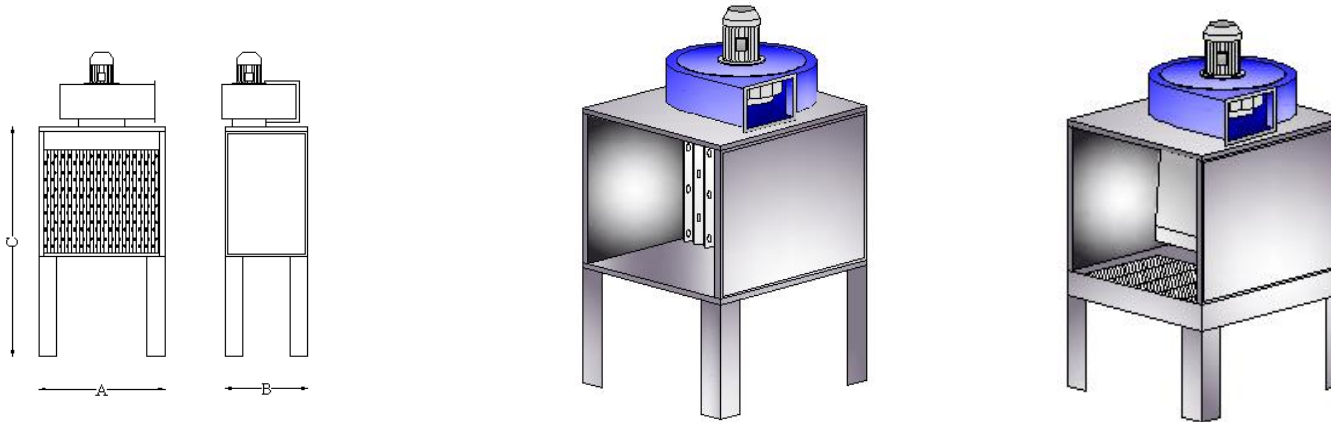

PICASSO MINI – DRY		Dimension		
Capacity	Power	A	B	C
2.000 mc/h	0,75 Hp	1060	1130	1950
With Active Carbon Filter				
PICASSO MINI –WATER		Dimension		
Power	Power	A	B	C
2.000 mc/h	0,75 Hp	1060	1130	1950
OPTIONAL				
Ceiling light				
Atex				

PAINING EXPRESS SELECTION

Simple, Solid, Safe



SUCTION BENCHES CLEAN

Made with galvanized sheet iron (not painted)



“CLEAN” series sanding benches for aspiration are made of strong press-bent galvanized sheet iron, with a work surface with eyelets.

They are indicated for aspiration of generic dust, with the exception of detonating or explosive dust.

The sanding benches series “CLEAN” must be connected to unit filtering with electric fan (not provided).

Standard accessories:

- 1. Sanding benches made of galvanized sheet iron,*
- 2. Bolts.*



PAINING EXPRESS SELECTION

SUCTION BENCHES CLEAN

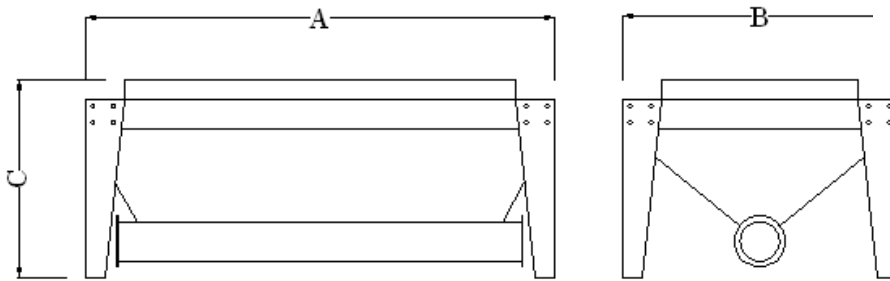

MODEL	A	B	C	Aspiration
CLEAN 200	2000	1000	900	∅ 200
CLEAN 250	2500	1000	900	∅ 200
CLEAN 300	3000	1000	900	∅ 250





PAINING SOLUTION FOR YOU

PAINING SOLUTION 4 YOU

 **SALVAMAC**
AIR & PAINTING



***PAIN*TING**



***PAIN*TING SOLUTION 4 YOU**

***PAIN*TING**



***PAIN*TING SOLUTION 4 YOU**



Model	
FILTERING GROUP	Cotton weave bag (Ø 500 mm x 1200 mm)
	Needled weave bag (Ø 500 mm x 1200 mm)
	PVC bag (Ø 500 mm x 1.200 mm) each one
	PVC bag (Ø 500 mm x 1.200 mm) 1 kg
	Bag-closure strip (Ø 500 mm)
	Cotton weave hole (Ø 180 mm L = 1.500 mm with snap-ring) and bottom plate
	Needled weave hole (Ø 180 mm L = 1.500 mm with snap-ring) and bottom plate
PAINTING	Filter ANDREA (9.28 x h =0.9 mt.)
	"GLASS" filter (Roll 1 mt. x 20 mt.)
	Cardboard cells with "GLASS" filter (dimensions 500x500) each one
	Cardboard cells with "GLASS" filter (dimensions 500x400) each one

SPARE PARTS





- EXPERIENCE
- QUALITY
- TEAM



THE NUMBERS

- 30 years of experience in the Air&painting
- + than 2000 machines and plant installed
- 2500 squared meter in 2 buildings
- 20 dealers working with us
- 10 exhibition per year
- +30% budget for Air&Painting per year 2019-2020





NOT ONLYWOOD

ONE WAY

NOT ONLY WOOD

METAL

PLASTIC

CHEMICAL

RECYCLING



SALVAMAC
AIR & PAINTING





SALVAMAC SP. Z O.O.
ul. Modrzewiowa 18,
62-081 Przeźmierowo
POLAND



IDEAS FACTORY
Via XX Settembre 105
31015 Conegliano TV
ITALY

PHOTO: GUY AROZ

STAY #AIR&PAINTING WITH US!!!



www.salvamac.com

info@salvamac.com

V 1.1

