

GRAULE

Maschinenbau

Machine ZS

Overview

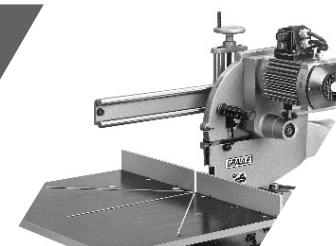

Horizontale Gehrung
Schnittbreite

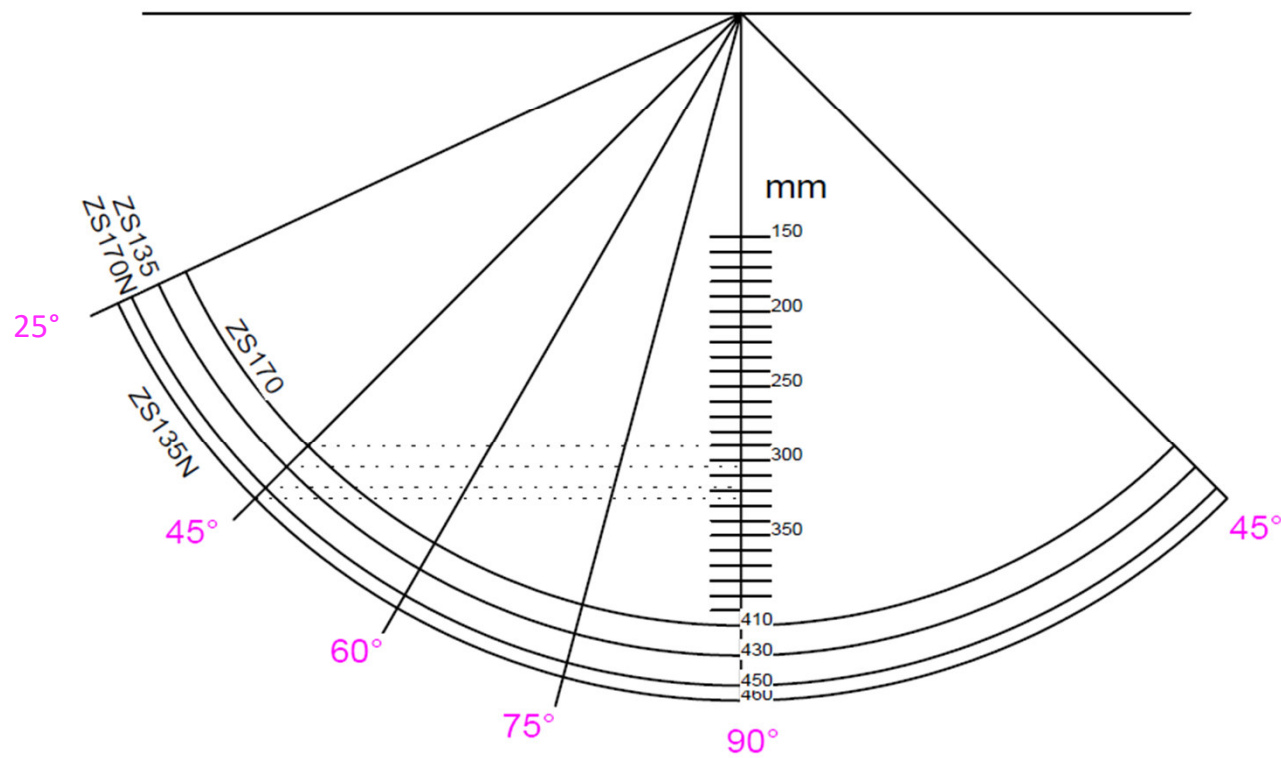

Vertikale Gehrung
Schnitthöhe

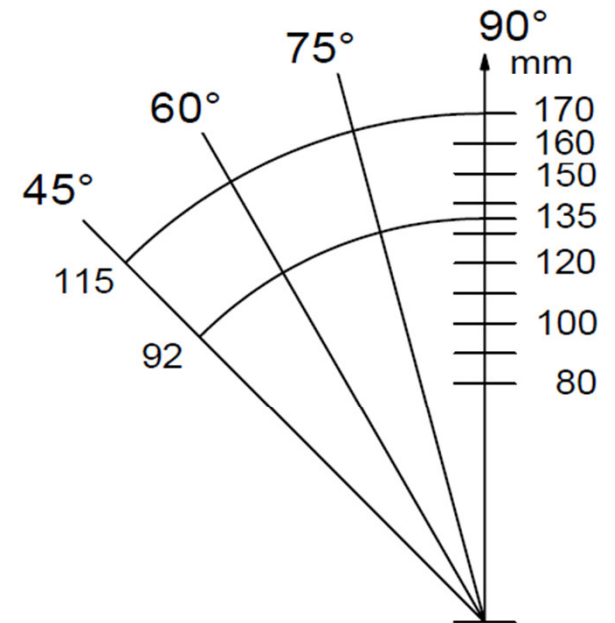

Horizontale Gehrung
Schnittbreite

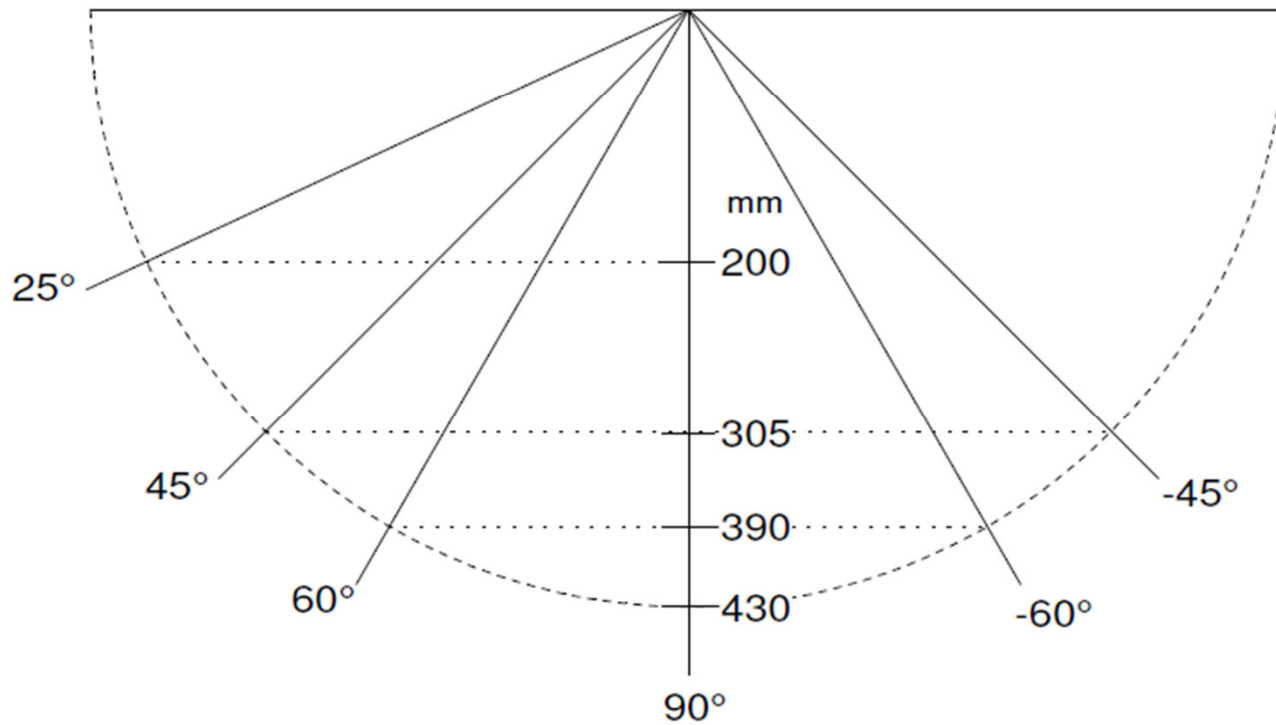

Vertikale Gehrung
Schnitthöhe

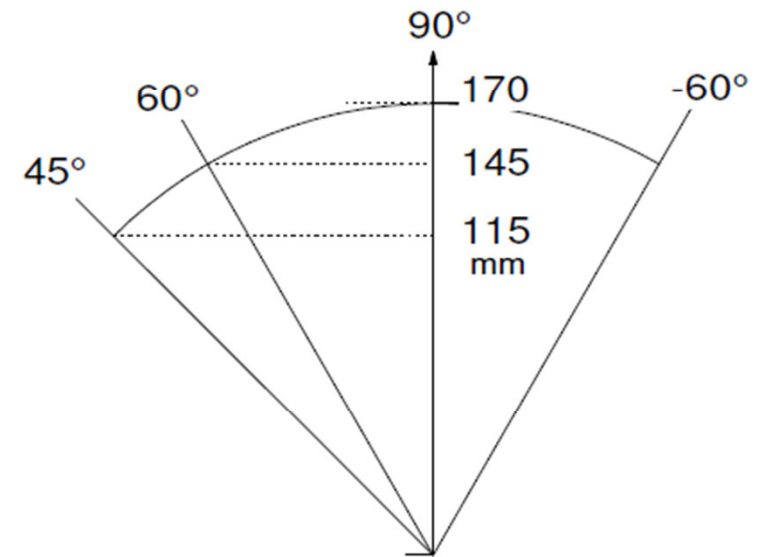

Horizontale Gehrung
Schnittbreite

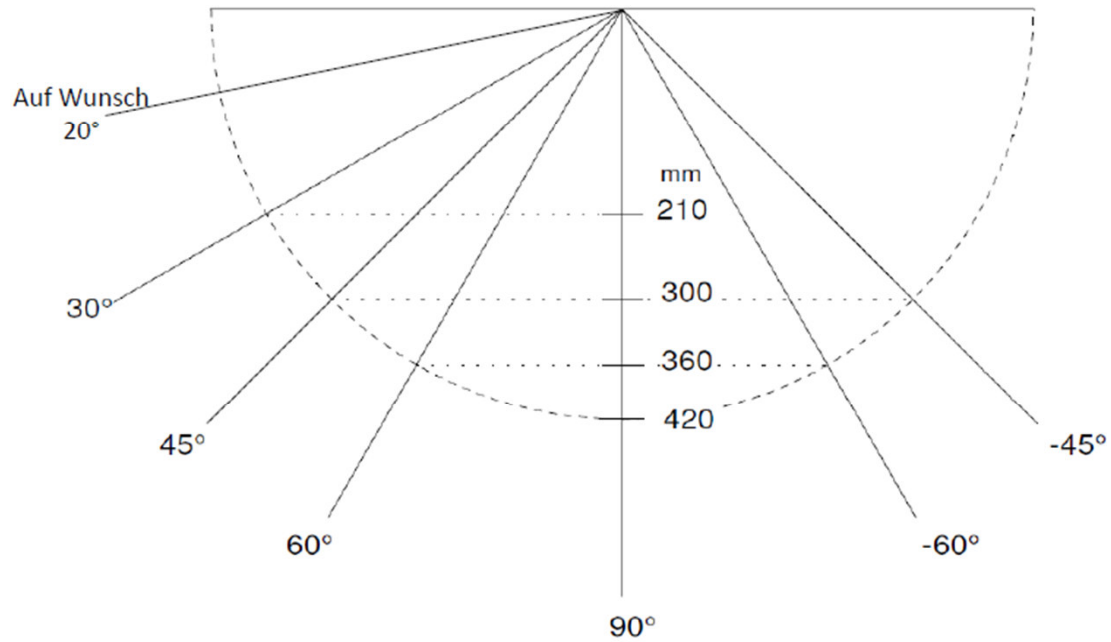

Vertikale Gehrung
Schnitthöhe

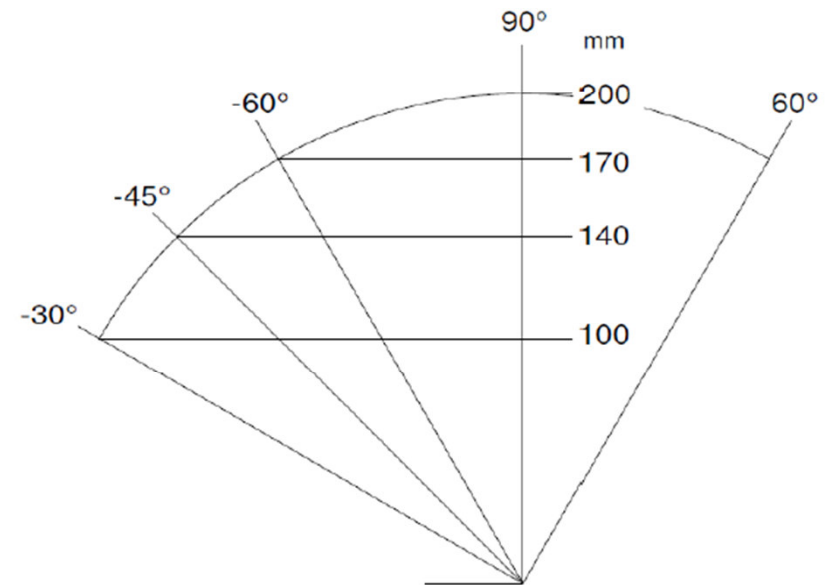

Hand Wheel – for tilting



Note

- Standard machine can be adjusted manually without a hand crank
- With roller conveyors on both sides of the machine, tilting from the front is also a sensible option for the customer, as he does not have to go to the rear of the machine

Hand Wheel – for tilting from the front



Note

- With roller conveyors on both sides of the machine, tilting from the front is also a sensible option for the customer, as he does not have to go to the rear of the machine
- (Here using the example of the Graule ZS 200 N)



Note

- Digital angle display
 - 1-Axis (Horizontal or Vertikal)
 - 2-Axis (Horizontal and Vertikal)
 - 3-Axis (High)

Machine ZS mobile

Overview

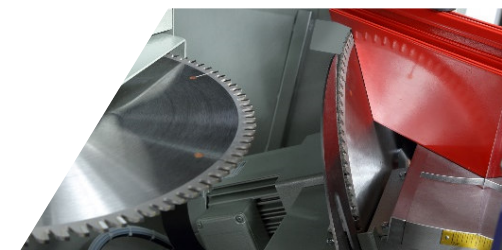
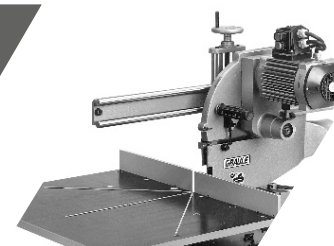



Note

- Standard are 1.5 meter roller conveyors to the left and right of the machine with steel rollers
- Left roller conveyor of type RLK with manually adjustable stop slide and additional auxiliary measuring rod for a measuring length of up to 3 meters

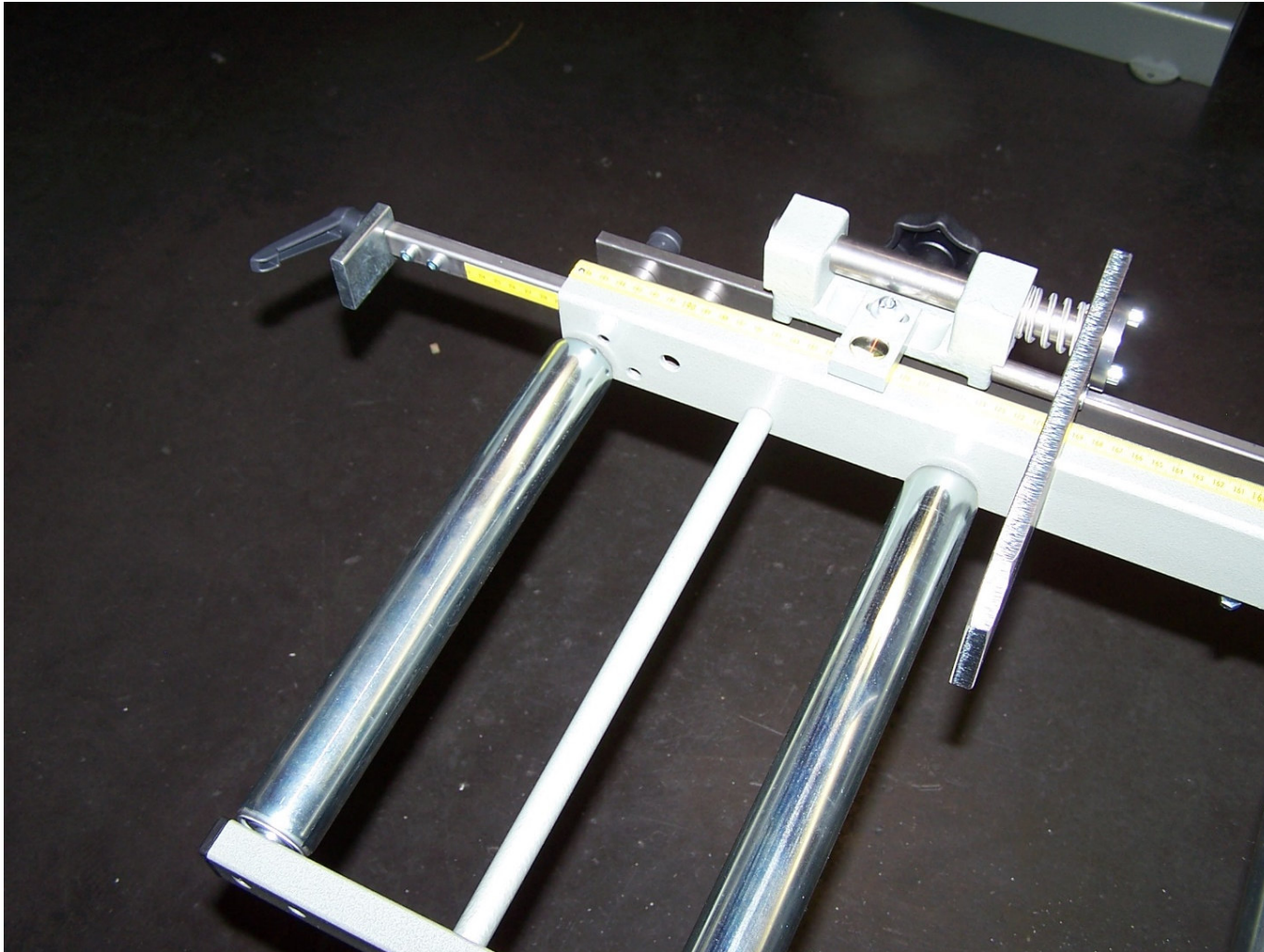

Note

- Included in the standard roller conveyors of type RLK
- Not applicable for length stop type RLH (handwheel), or for heavy roller conveyors ST-60



Anmerkung

- The roller conveyors and the base can be adjusted as required
- The length of each side can be extended to up to 6 meters
- Length stop type RLK can also be converted into a length stop type RLH (with handwheel)
- For heavy Wook working like carpentry or similar we recommend the heavy roller conveyors of the type ST-60 with steel rollers

Roller Conveyors

Overview

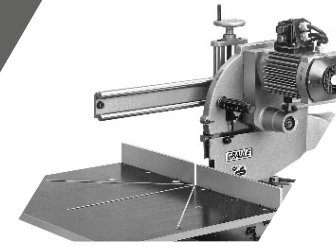

Overview of the 2 Types

Standard System

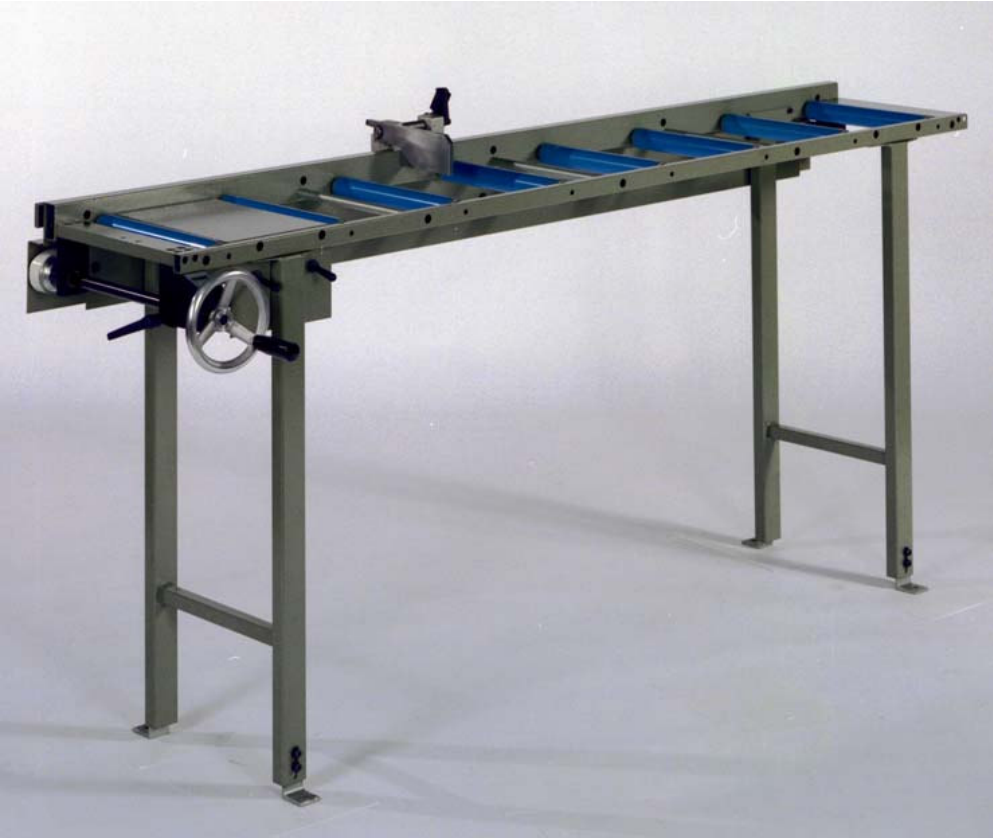

ST-60



Standard System for lighter woods, PVC and Aluminium profiles

- Design: Ball bearing plastic rolls with 40 mm diameter, roll width 300 mm, roller distance 300 mm,
- Roller conveyor height 885 +/- 10 mm, incl. connecting part for Radial Arm Saws type ZS...
- **Important:** Please indicate connecting side and type of the machine!
- **Type RO** : Roller Conveyor complete with stands and connecting part
- **Type RLK:** Roller Conveyor / Length Stop System with scale and flip-stop. Cpl. with stands and connecting part
- **Type RLH:** Roller conveyor / Length Stop System with flip-stop, length adjustment by hand-wheel from working place and pneumatic clamp of flip-stop, electronic digital read out display, compl. with stands and connecting part
- Roller conveyor with length stop system Type RLH and/or RLHK can be supplied with **Direct Magnetic Tape Measuring System**.
- Additional prices for **LED read-out unit, 230 V (for deep temperature): 190,-- Euro**
- Additional price for **roll width 400 mm** : 64,-- Euro / mtr. Additional price for **flip stop up to the saw blade:** 140,-- Euro
- Additional price for **steel rolls:** 43,-- Euro/mtr. / Additional price for intermedia plate: 68,-- Euro/mtr.

ST-60

- Design: Ball bearing steel rolls with 60 mm diameter, roll width 400 mm, roller distance 200 mm, carrying capacity per roll 80 kg,
- Roller conveyor height: 885 +/-10 mm, incl. connecting part for the Radial Arm Saws type ZS ...
- **Important:** Please indicate connecting side and type of the machine!
- **Type RO-ST60:** Roller Conveyor
- **Type RLK-ST60:** Roller Conveyor / Length Stop System. Heavy roller conveyor Type RO-ST60 with scale and normal flip-stop system of type RLK
- **Type RLH-ST60:** Roller Conveyor / Length Stop System flip-stop system adjustable by handwheel from working place and pneumatic fixing, electronic digital read-out display. Constuction length= length + 0,8 mtr.
- Additional prices for **LED read-out unit, 230 V (for deep temperature): 190,-Euro**
- Additional prices for cable track at RLH-ST60: **160,--Euro/mtr.**(starting from 8 mtr. recommendable)
- **Type RLE-ST60:** Roller Conveyor / Electronic Length Stop System Type TIGER STOP with programmable flip stop system
- Further accessories for TIGER STOP system see our separate brochure.
- **Roller support Typ RB:** Roller support heavy duty: **490,-- Euro**
- The Roller Conveyor Type RLH-ST60 or RLK-ST60 can be delivered with a direct Magnetic Tape Measuring System.



Type RLK

- manual length system
- roller conveyor length stop with stop slide that folds away to the rear



Type RLH

- Hand wheel length system
- roller conveyor length stop with material stop that folds away to the rear, stop slide adjustable via handwheel from the workstation, electronic digital dimension display



Type RLK

- manual length system
- roller conveyor length stop with stop slide that folds away to the rear



Type RLH

- Hand wheel length system
- roller conveyor length stop with material stop that folds away to the rear, stop slide adjustable via handwheel from the workstation, electronic digital dimension display

Standard EP7 (with Battery)



EP 6 (230V) – Extra Charge

- Advantage: strong red LED display. Significantly better readability

